

ISS.	DATE	E.C.N.	DESCRIPTION
3	15-Jan-07	1/07/1199	SCALLOP SIZE INCREASED

© 2007 CARCLO  
ALL DIMENSIONS IN mm

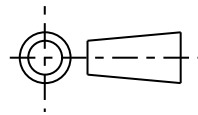

CARCLO TECHNICAL PLASTICS (SLOUGH)  
111 BUCKINGHAM AVE, SLOUGH  
SL1 4PF, ENGLAND  
TEL: +44 1753 575011 FAX: +44 1753 811359  
e-mail: design@carclo-optics.com}

CUSTOMER DRAWING

GENERAL TOLERANCES (UNLESS STATED)

LINEAR	ANGULAR
X +/- 0.25	X +/- 1°
X.X +/- 0.1	X.X +/- 0.5°
X.XX +/- 0.05	X.XX +/- 0.1°

CUSTOMER

CARCLO

TITLE

LED OPTIC 26.5MM DIAMETER

DRAWN

DATE

AJD

03-Feb-04

CHK'D

DATE

APP'D

DATE

SCALE

2:1

CARCLO PART No.

10048

SIZE

A4

CARCLO DRG. No.

60367

SHEET

1 OF 1

MATERIAL: POLYCARBONATE

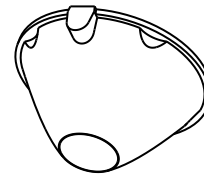
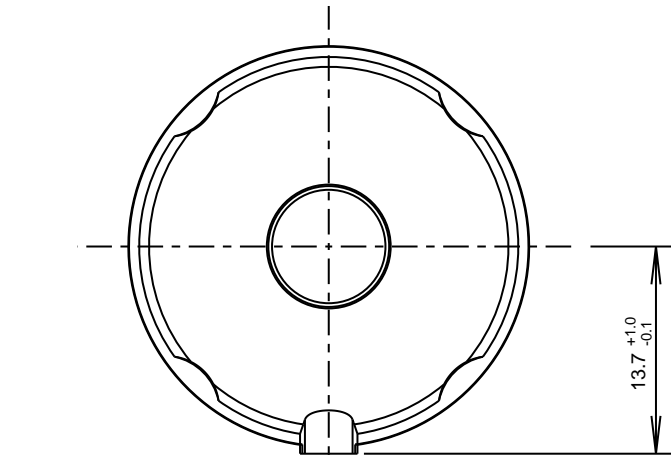

SCALE 1:1  
GENERAL VIEW

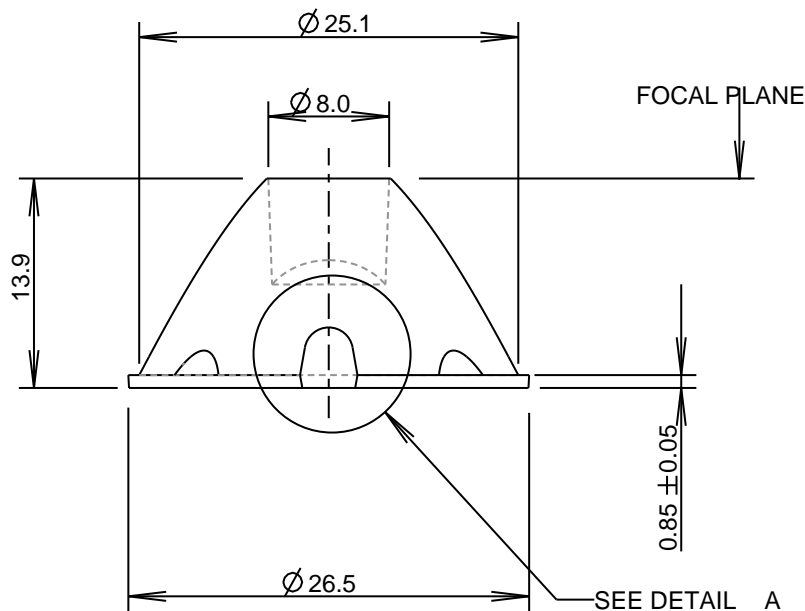

DETAIL A  
SCALE 4:1

