

SPECIFICATION

MODEL : SPHWHTL3D305E6W0H3

[Approved Rank : $V_F(E6)$, $CCT(W0)$, $Im_v(H3)$]

3535 Ceramic PKG



CUSTOMER :		
DRAWN	CHECKED	APPROVED

SAMSUNG LED		
DRAWN	CHECKED	APPROVED

SAMSUNG LED CO.,LTD.314. MAETAN3-DONG, YEONGTONG-KU,
SUWON-SI,GYUNGKI-DO,KOREA,442-743

Contents

1.	Product Outline	-----	3
2.	Absolute Maximum Rating	-----	3
3.	Characteristics	-----	3
4.	Typical Characteristics Graph	-----	6
5.	Outline Drawing & Dimension	-----	7
6.	Reliability Test Items & Conditions	-----	8
7.	Solder Conditions	-----	9
8.	Taping Dimension	-----	10
9.	Label Structure	-----	11
10.	Lot Number	-----	11
11.	Reel Packing Structure	-----	12
12.	Aluminium Packing Bag	-----	13
13.	Precaution For Use	-----	14
14.	Hazard Substance Analysis	-----	15
15.	Revision History	-----	18

1. Product Outline

1) Features

- . Ceramic chip PKG (3.5 x 3.5 x 2.1mmT)
- . Wide Beam Angle ($\Delta\theta$: 122° x 122°) for uniform illuminance
- . InGaN/GaN MQW LED with Long-time Reliability
- . Lead (Pb) free product – RoHS compliant

2) Applications

- . Substitution for Incandescent lamp
- . Substitution for Fluorescent lamp
- . Substitution for Signal lamp
- . Other applications

2. Absolute Maximum Rating

- 1) Operation Forward Current ($T_a = 25^\circ\text{C}$) 1500 mA
- 2) Thermal Resistance ($R_{th,j-c}$) 6.1 K/W
- 3) LED Junction Temperature (T_J) 150°C
- 4) Operating Temperature Range (T_{opr}) -10°C ~ 80°C
- 5) Storage Temperature Range (T_{stg}) -10°C ~ 100°C

3. Characteristics

1) Electro-Optical characteristics

($T_a : 25^\circ\text{C}$)

CCT(K)	Item	Unit	Condition	Rank	Min	Typ	Max
2700K	Luminous Flux	lm	$I_F = 350 \text{ mA}$	H3	110	-	140
	Forward Voltage (V_F)	V		E6	2.7		3.3
	CRI			-	80	-	
	View Angle	°				120°	
	Size	mm			3.5 x 3.5 x 2.1		

2) Chromaticity Diagram

 ($T_a : 25^{\circ}\text{C}$)

3) Chromaticity Coordinates

Table	Rank	x	y	Table	Rank	x	y
2700K (W0)	W1	0.4373	0.3893	2700K (W0)	W9	0.4465	0.4071
		0.4418	0.3981			0.4513	0.4164
		0.4475	0.3994			0.4573	0.4178
		0.4428	0.3906			0.4523	0.4085
	W2	0.4428	0.3906		WA	0.4523	0.4085
		0.4475	0.3994			0.4573	0.4178
		0.4532	0.4008			0.4634	0.4193
		0.4483	0.3919			0.4582	0.4099
	W3	0.4483	0.3919		WB	0.4582	0.4099
		0.4532	0.4008			0.4634	0.4193
		0.4589	0.4021			0.4695	0.4207
		0.4538	0.3931			0.4641	0.4112
	W4	0.4538	0.3931		WC	0.4641	0.4112
		0.4589	0.4021			0.4695	0.4207
		0.4646	0.4034			0.4756	0.4221
		0.4593	0.3944			0.4700	0.4126
	W5	0.4418	0.3981		WD	0.4513	0.4164
		0.4465	0.4071			0.4562	0.4260
		0.4523	0.4085			0.4624	0.4274
		0.4475	0.3994			0.4573	0.4178
	W6	0.4475	0.3994		WE	0.4573	0.4178
		0.4523	0.4085			0.4624	0.4274
		0.4582	0.4099			0.4687	0.4289
		0.4532	0.4008			0.4634	0.4193
W7	0.4532	0.4008	WF	0.4634	0.4193		
	0.4582	0.4099		0.4687	0.4289		
	0.4641	0.4112		0.4750	0.4304		
	0.4589	0.4021		0.4695	0.4207		
W8	0.4589	0.4021	WG	0.4695	0.4207		
	0.4641	0.4112		0.4750	0.4304		
	0.4700	0.4126		0.4813	0.4319		
	0.4646	0.4034		0.4756	0.4221		

4) VF Rank

Parameter	Symbol	Condition	Rank	Rank	Min.	Typ.	Max.
VF	V _F	I _F = 350mA	E6	E3	2.7	-	3.0
				H3	3.0	-	3.3

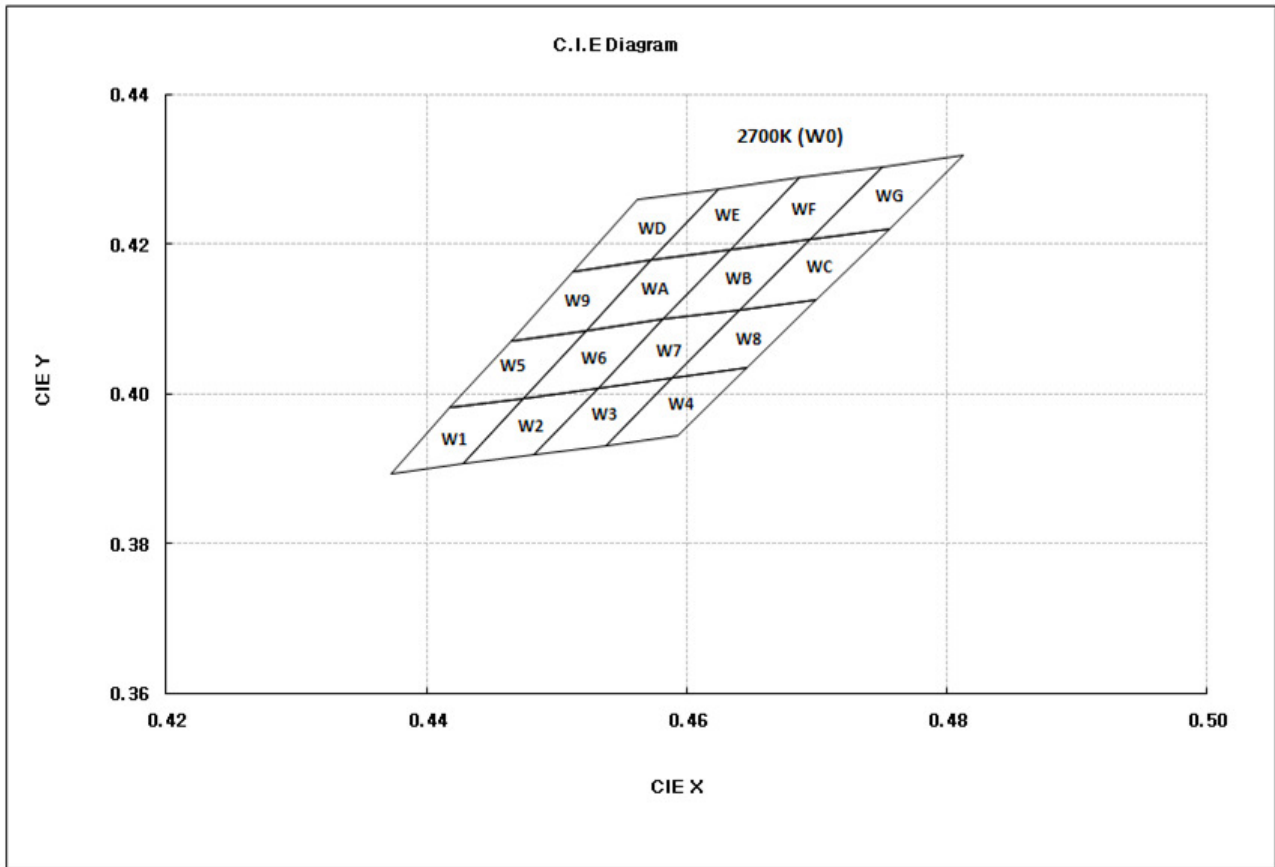
5) Luminous Flux Rank

Parameter	Symbol	Condition	Rank	Rank	Min.	Typ.	Max.
lm	lm	I _F = 350mA	H3	H1	110	-	120
				J1	120	-	130
				K1	130	-	140

4. Typical Characteristics Graph

($T_a = 25^\circ\text{C}$)

Normalized I_m vs. Forward Current

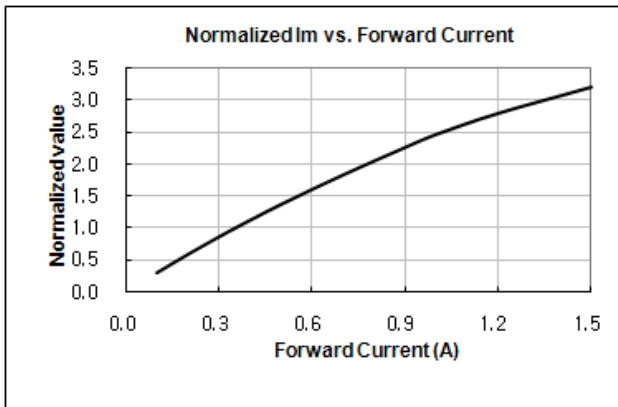

Forward Current vs. Forward Voltage

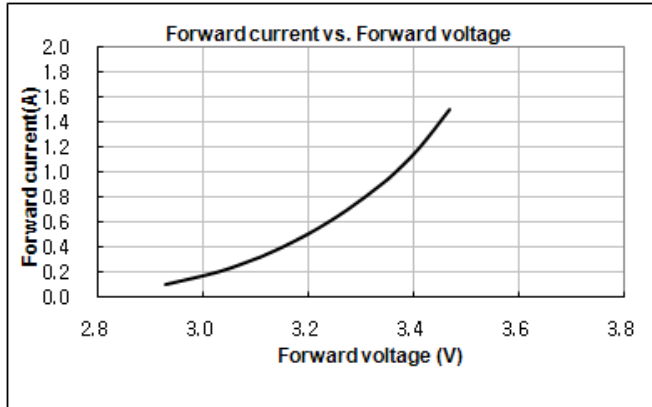

View Angle

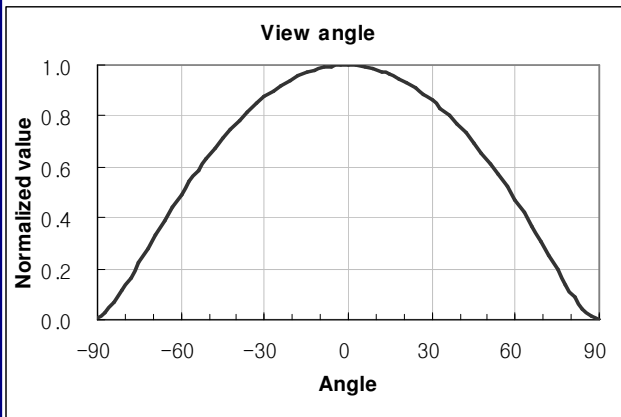

Normalized flux(I_m) vs. Junction temp

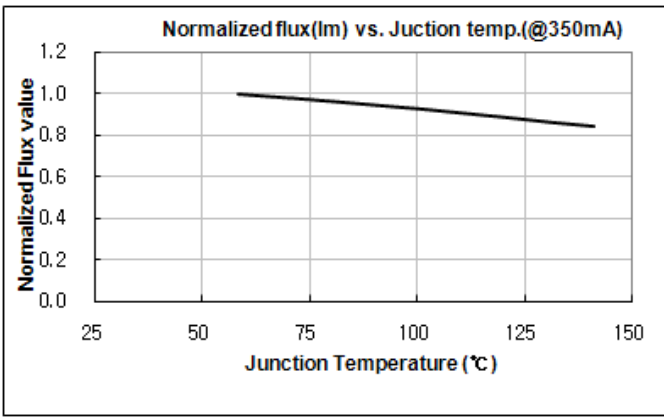

Spectrum Distribution

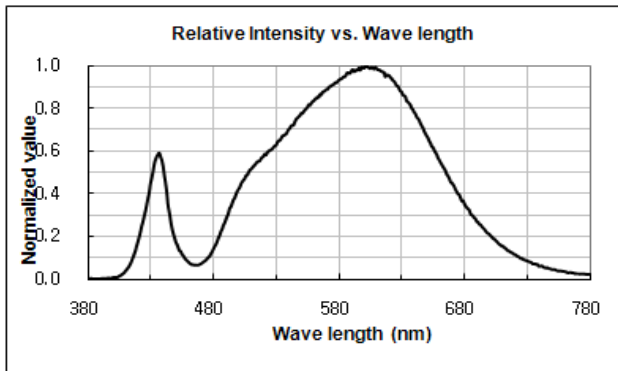

Derating Curve

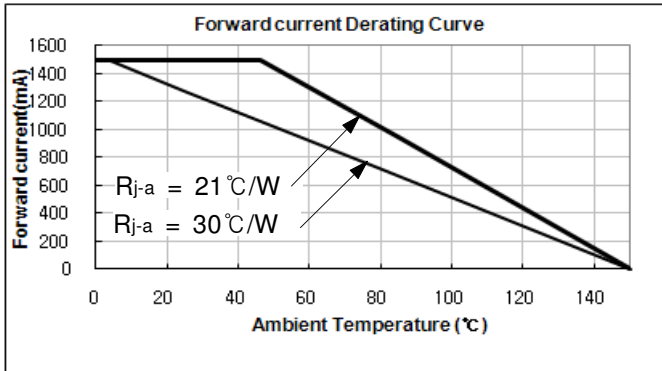

Forward Current vs. Color x,y

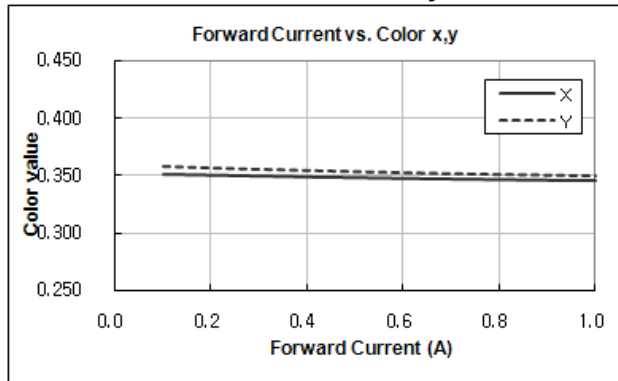

View angle vs. CCT

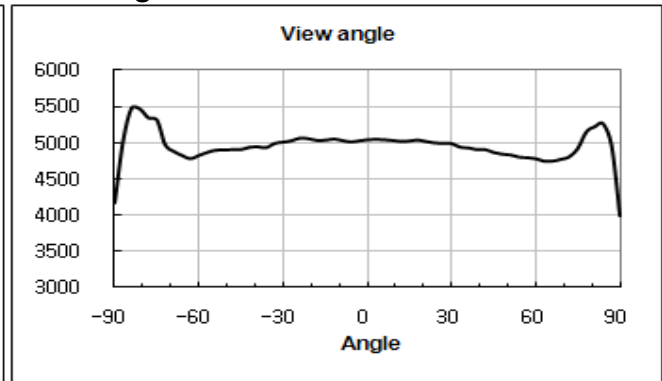

5. Outline Drawing & Dimension

unit : mm
Tolerance : ± 0.15

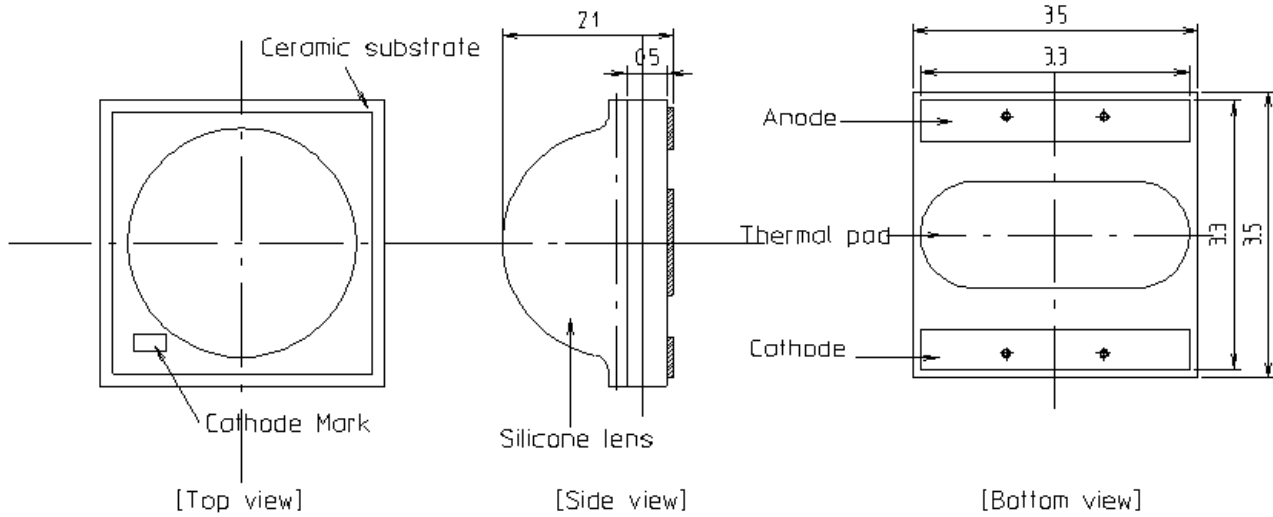

Recommended Land Pattern

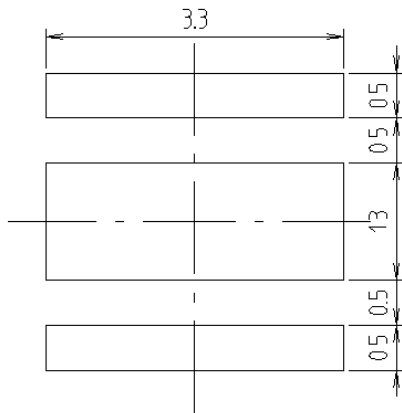

Circuit

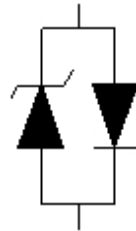

* 2D CAD data are available upon request.

6. Reliability Test Items and Conditions

1) Test Items and Results

Test Items	Test Conditions	Test Hours/Cycles	Sample No.
Room Temperature Life Test	25°C, DC 700 mA	1000 Hr	0/22
High Temperature humidity Life Test	85°C, 85%, DC 600 mA	1000 Hr	0/22
High Temperature Life Test	85°C, DC 600 mA	1000 Hr	0/22
Low Temperature Life Test	-40°C, DC 700 mA	1000 Hr	0/22
Temperature Humidity Cycle	-10°C ↔ 25°C 95%RH ↔ 85°C 95%RH 350mA, 95%RH, 24hrs/1cycle	10 Cycles	0/22
Thermal Shock	-45 °C/15 min ↔ 125 °C/ 15 min. Temp.change within 5min.	100 Cycles	0/22
High Temperature Storage	Ta=120°C	1000 Hr	0/11
Low Temperature Storage	Ta=-40°C	1000 Hr	0/11
ESD(HBM)	R1=10MΩ, R2=1.5KΩ, C=100pF, V=±5KV, 5Times	5 Times (±5kV)	0/5

2) Criteria for Judging the Damage

Item	Symbol	Test Condition [T _a = 25°C]	Limit	
			Min.	Max.
Forward Voltage	V _F	350 mA	L.S.L.* T.B.D	U.S.L. * T.B.D
Luminous flux	Im	350 mA	L.S.L. * T.B.D	U.S.L. * T.B.D

* U.S.L. : Upper Standard Level L.S.L. : Lower Standard Level

7. Solder Conditions

1) Reflow Conditions (Pb Free)

Reflow Frequency : 2 times max.

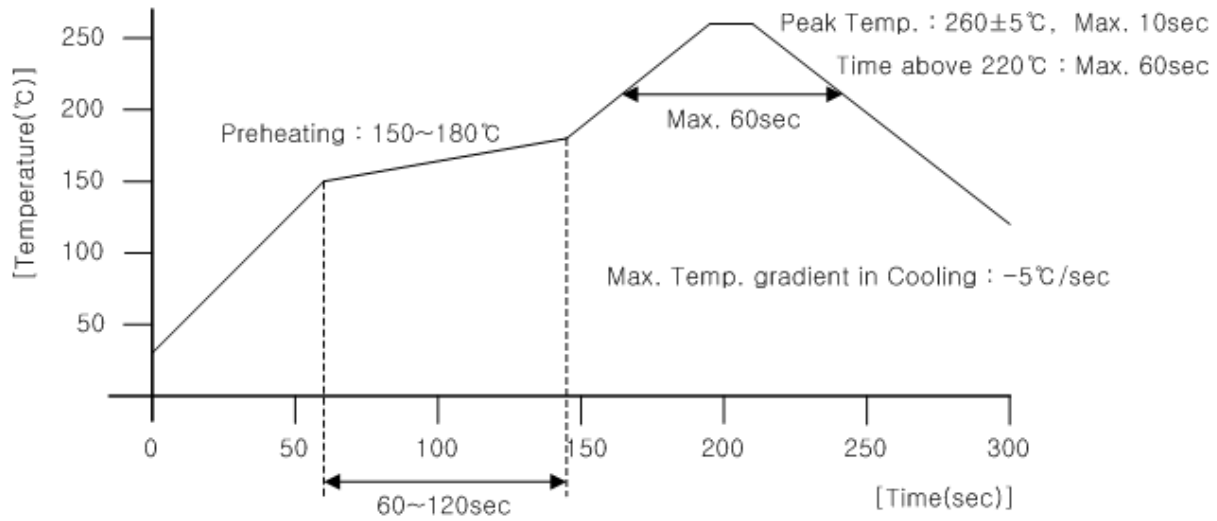

8. Taping Dimension

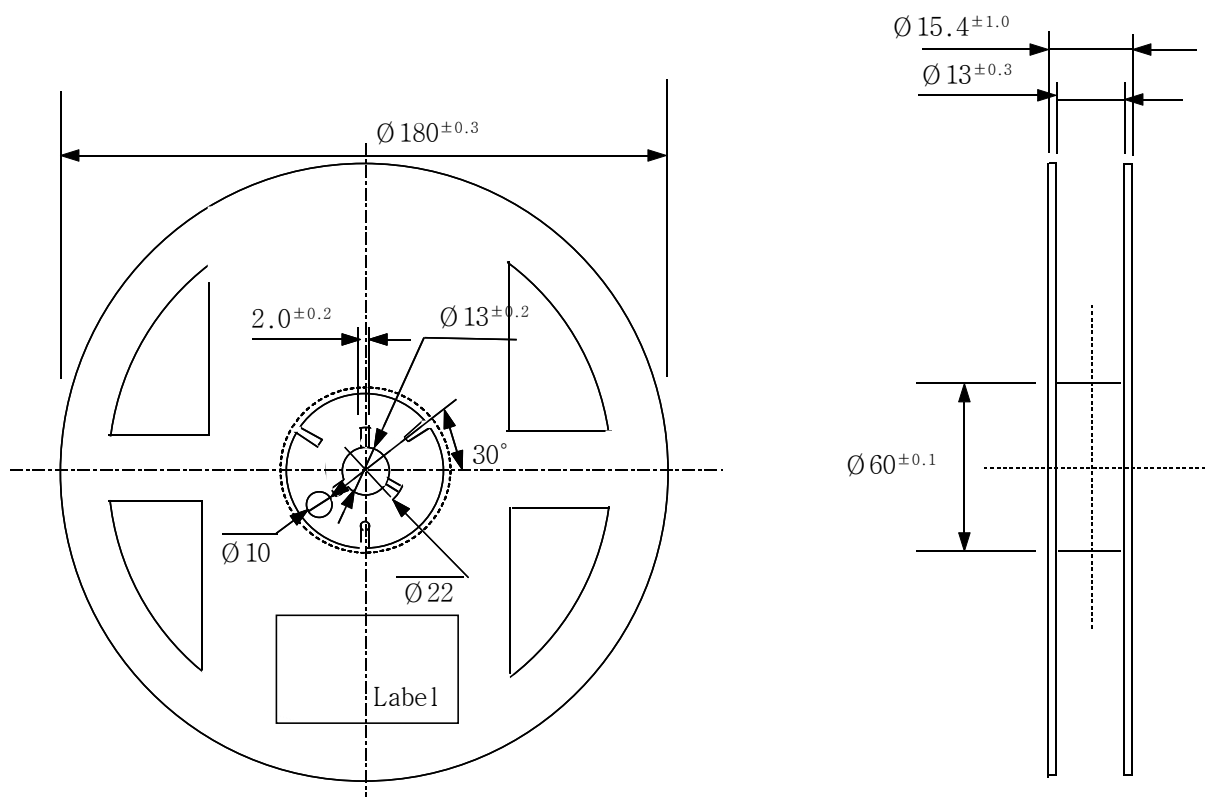
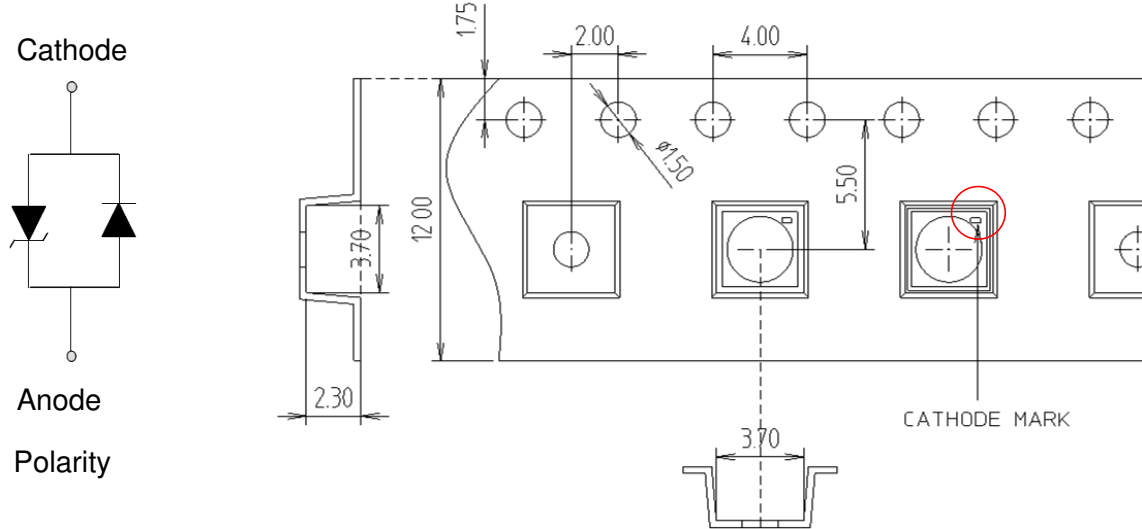

- (1) Quantity : The quantity/reel to be 1,000 pcs.
- (2) Cumulative Tolerance : Cumulative tolerance/10 pitches to be ± 0.2 mm
- (3) Adhesion Strength of Cover Tape : Adhesion strength to be 0.1-0.7N when the cover tape is turned off from the carrier tape at 10° angle to be the carrier tape.
- (4) Packaging : P/N, Manufacturing data code no. and quantity to be indicated on a damp proof package.

9. Label Structure



Rank Code

/E6/ : VF Rank (refer to page 3)

/W0/ : Chromaticity Coordinate Rank, CIE (refer to page 4)

/H3/ : Luminous Flux (refer to page 4)

10. Lot Number

The Lot number is composed of the following characters



●◎◇◆□■△△△ / |▲▲▲ / 1000PCS

- : Production Site (S:SAMSUNG LED, G:Gosin China)
- ◎ : L (LED)
- ◇ : Product State (A:Normality, B:Bulk, C:First Production, R:Reproduction, S:Sample)
- ◆ : Year (S:2008, T:2009, U:2010...)
- : Month (1 ~ 9, A, B)
- : Day (1 ~ 9, A, B ~ V)
- △ : SAMSUNG LED Product Number (1 ~ 999)
- ▲ : Reel Number (1 ~ 999)

11. Reel Packing Structure

Reel

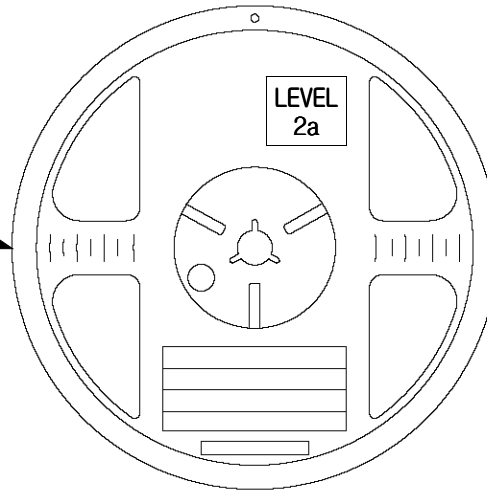

Aluminum Vinyl Bag

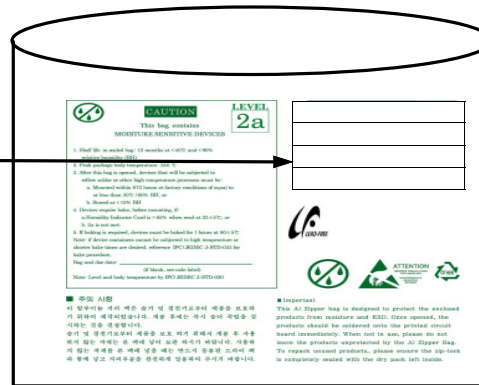

Material : Paper(SW3B(B))

TYPE	SIZE(mm)		
	a	b	c
7inch	250	225	190

① SIDE

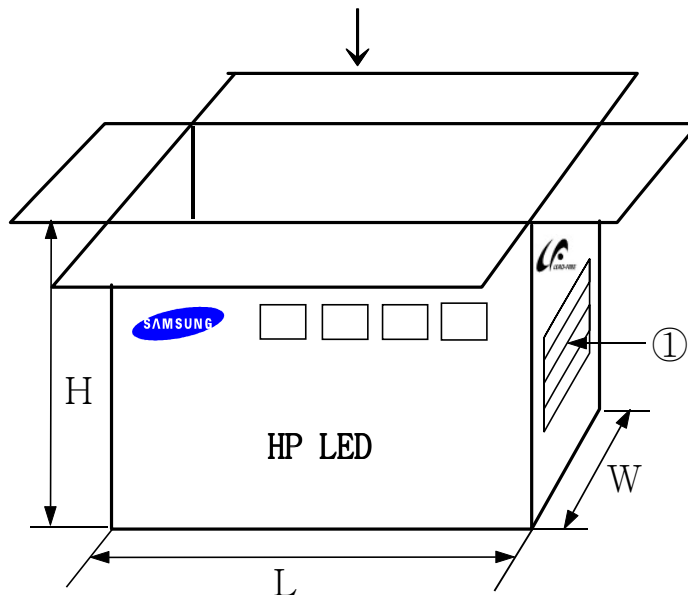
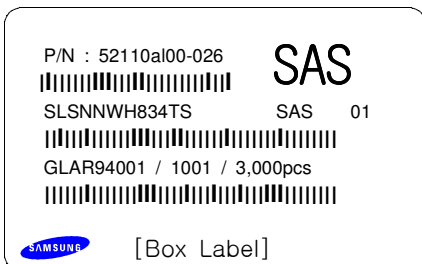

12. Aluminum Packing Bag



CAUTION

LEVEL
2a

This bag contains
MOISTURE SENSITIVE DEVICES

1. Shelf life in sealed bag: 12 months at <math>< 40^{\circ}\text{C}</math> and <math>< 90\%</math> relative humidity (RH)
 2. Peak package body temperature: 240°C
 3. After this bag is opened, devices that will be subjected to reflow solder or other high temperature processes must be:
 - a. Mounted within 672 hours at factory conditions of equal to or less than 30°C / 60% RH, or
 - b. Stored at <math>< 10\%</math> RH
 4. Devices require bake, before mounting, if:
 - a. Humidity Indicator Card is > 65% when read at $23 \pm 5^{\circ}\text{C}$, or
 - b. 2a is not met.
 5. If baking is required, devices must be baked for 1 hours at $60 \pm 5^{\circ}\text{C}$
- Note: if device containers cannot be subjected to high temperature or shorter bake times are desired, reference IPC/JEDEC J-STD-033 for bake procedure,
- Bag seal due date: _____

(if blank, see code label)

Note: Level and body temperature by IPC/JEDEC J-STD-020

P/N : 52110al00-026



SLSNNWH834TS SAS 01



GLAR94001 / 1001 / 3,000pcs



ATTENTION
OBSERVE PRECAUTIONS
FOR HANDLING
ELECTROSTATIC
SENSITIVE
DEVICES



■ 주의 사항

이 알루미늄 지퍼 백은 습기 및 정전기로부터 제품을 보호하기 위하여 제작되었습니다. 개봉 후에는 즉시 솔더 작업을 실시하는 것을 권장합니다.

습기 및 정전기로부터 제품을 보호 하기 위해서 개봉 후 사용하지 않는 자재는 본 팩에 넣어 보관 하시기 바랍니다. 사용하지 않는 자재를 본 팩에 넣을 때는 반드시 동봉된 드라이 팩과 함께 넣고 지퍼부분을 완전하게 밀봉하여 주시기 바랍니다.

■ Important

This Al Zipper bag is designed to protect the enclosed products from moisture and ESD. Once opened, the products should be soldered onto the printed circuit board immediately. When not in use, please do not leave the products unprotected by the Al Zipper Bag. To repack unused products., please ensure the zip-lock is completely sealed with the dry pack left inside.

Silica gel & Humidity Indicator Card in Aluminum Bag

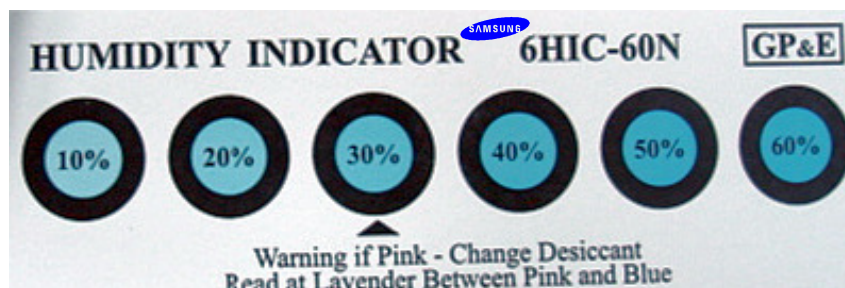

13. Precaution for use

- 1) For overcurrent-protection, customers are recommended to apply resistors connected in series with the LEDs to mitigate sudden change of the forward current caused by shift of the forward voltage.
- 2) This device should not be used in any type of fluid such as water, oil, organic solvent, etc. When cleaning is required, IPA is recommended as cleaning agent. Solvent-based cleaning agent such as Zestron^(R) may damage the silicone resins used in the device.
- 3) When the device is in operation, the forward current should be carefully determined considering the maximum ambient temperature and the corresponding junction temperature.
- 4) LEDs must be stored in a clean environment. If the LEDs are to be stored for 3 months or more after being shipped from Samsung LED, they should be packed with a nitrogen-filled container.
(Shelf life of sealed bags: 12 months, temp. 0~40°C, 20~70%RH)
- 5) After storage bag is open, device subject to soldering, solder reflow, or other high temperature processes must be:
 - a. Mounted within 168 hours (7 days) at an assembly line with a condition of no more than 30°C/60%RH.
 - b. Stored at <10% RH.
- 6) Repack unused Products with anti-moisture packing, fold to close any opening and then store in a dry place.
- 7) Devices require baking before mounting, if humidity card reading reaches 60% at 23±5°C.
- 8) Devices must be baked for 24hours at 65±5°C, if baking is required.
- 9) The LEDs are sensitive to the static electricity and surge current. It is recommended to use a wrist band or anti-electrostatic glove when handling the LEDs.
If voltage exceeding the absolute maximum rating is applied to LEDs, it may cause damage or even destruction to LED devices.
Damaged LEDs may show some unusual characteristics such as increase in leakage current, lowered turn-on voltage, or abnormal lighting of LEDs at low current.

14. Hazard Substance Analysis

**Test Report No.** F690501/LF-CTSAYAA11-02162

Issued Date: January 21, 2011

Page 1 of 5

To: **SAMSUNG LED CO., LTD.**
 314, Maetan-dong
 Yeongtong-gu
 Suwon-city
 GYEONGGI-DO 443-370
 Korea

The following merchandise was submitted and identified by the client as :

SGS File No. : AYAA11-02162
 Product Name : 3535 Ceramic PKG
 Item No./Part No. : N/A
 Received Date : Jan 18, 2011
 Test Period : Jan 19, 2011 to Jan 20, 2011
 Test Performed : SGS Testing Korea tested the sample(s) selected by applicant with following results
 Test Results : For further details, please refer to following page(s)
 Comments : By the applicant's specific request, the sampling and testing was performed only for the part indicated in the photo without disassembly.

Timothy Jeon
 Jinhee Kim
 Cindy Park
 Jerry Jung/ Testing Person

SGS Testing Korea Co. Ltd.

Jeff Jang / Chemical Lab Mgr

The document is issued by the Company which is its General Conditions of Service placed on file, available on request or e-mail at www.sgs.com and, for electronic format documents, subject to Terms and Conditions for Electronic Documents at www.sgs.com. Attention is drawn to the limitation of liability, indemnification and jurisdiction clause stated therein. Any holder of this document is advised that information contained therein reflects the Company's findings at the time of its preparation only and under the terms of Client's authorization, if any. The Company's sole responsibility is to its Client and this document does not constitute a guarantee or a warranty from compliance with any right and obligation under the associated document. This document cannot be reproduced except in full, without prior written approval of the Company. Any unauthorized alteration, forgery or falsification of the content or appearance of this document is strictly prohibited and may be prosecuted in the future. A document of this type is intended for internal use only. (Some electronic scanned file results shown in this test report may vary to the original document and such samples are retained for 90 days only.)

14. Hazard Substance Analysis



Test Report No. F690501/LF-CTSAYAA11-02162

Issued Date: January 21, 2011

Page 2 of 5

Sample No. : AYAA11-02162.001
Sample Description : 3535 Ceramic PKG
Item No./Part No. : N/A
Comments : Materials are Ceramic, Silicone.

Heavy Metals

Test Items	Unit	Test Method	MDL	Results
Cadmium (Cd)	mg/kg	With reference to IEC 62321:2008, ICP	0.5	N.D.
Lead (Pb)	mg/kg	With reference to IEC 62321:2008, ICP	5	N.D.
Mercury (Hg)	mg/kg	With reference to IEC 62321:2008, ICP	2	N.D.
Hexavalent Chromium (Cr VI)	mg/kg	With reference to IEC 62321:2008, UV-VIS	1	N.D.

Flame Retardants-PBBs/PBDEs

Test Items	Unit	Test Method	MDL	Results
Monobromobiphenyl	mg/kg	With reference to IEC 62321:2008, GC-MS	5	N.D.
Dibromobiphenyl	mg/kg	With reference to IEC 62321:2008, GC-MS	5	N.D.
Tribromobiphenyl	mg/kg	With reference to IEC 62321:2008, GC-MS	5	N.D.
Tetrabromobiphenyl	mg/kg	With reference to IEC 62321:2008, GC-MS	5	N.D.
Pentabromobiphenyl	mg/kg	With reference to IEC 62321:2008, GC-MS	5	N.D.
Hexabromobiphenyl	mg/kg	With reference to IEC 62321:2008, GC-MS	5	N.D.
Heptabromobiphenyl	mg/kg	With reference to IEC 62321:2008, GC-MS	5	N.D.
Octabromobiphenyl	mg/kg	With reference to IEC 62321:2008, GC-MS	5	N.D.
Nonabromobiphenyl	mg/kg	With reference to IEC 62321:2008, GC-MS	5	N.D.
Decabromobiphenyl	mg/kg	With reference to IEC 62321:2008, GC-MS	5	N.D.
Monobromodiphenyl ether	mg/kg	With reference to IEC 62321:2008, GC-MS	5	N.D.
Dibromodiphenyl ether	mg/kg	With reference to IEC 62321:2008, GC-MS	5	N.D.
Tribromodiphenyl ether	mg/kg	With reference to IEC 62321:2008, GC-MS	5	N.D.
Tetrabromodiphenyl ether	mg/kg	With reference to IEC 62321:2008, GC-MS	5	N.D.
Pentabromodiphenyl ether	mg/kg	With reference to IEC 62321:2008, GC-MS	5	N.D.
Hexabromodiphenyl ether	mg/kg	With reference to IEC 62321:2008, GC-MS	5	N.D.
Heptabromodiphenyl ether	mg/kg	With reference to IEC 62321:2008, GC-MS	5	N.D.
Octabromodiphenyl ether	mg/kg	With reference to IEC 62321:2008, GC-MS	5	N.D.
Nonabromodiphenyl ether	mg/kg	With reference to IEC 62321:2008, GC-MS	5	N.D.
Decabromodiphenyl ether	mg/kg	With reference to IEC 62321:2008, GC-MS	5	N.D.

NOTE: (1) N.D. = Not detected.(<MDL)
 (2) mg/kg = ppm
 (3) MDL = Method Detection Limit
 (4) - = No regulation
 (5) ** = Qualitative analysis (No Unit)
 (6) * = Boiling-water-extraction:
 Negative = Absence of CrVI coating
 Positive = Presence of CrVI coating; the detected concentration in boiling-water-extraction solution is equal or greater than 0.02 mg/kg with 50 cm² sample surface area.

This document is issued by the Company which is its General Conditions of Service posted on its website or issued in accordance with the applicable laws and regulations, subject to Terms and Conditions for Reference Documents at www.samsungled.com. All information contained herein reflects the Company's findings at the time of its issuance only and unless the laws of Korea indicate, it may. The Company and its subsidiaries do not assume any liability for any damage or loss of any kind, including direct, indirect, or consequential damages, arising from the use of this document or any information contained herein. This document cannot be reproduced, stored in a retrieval system, or transmitted in any form or by any means, electronic, mechanical, photocopying, recording, or by any information storage and retrieval system, without prior written approval of the Company. Any unauthorized alteration, copying or distribution of the contents of this document is strictly prohibited and will be prosecuted to the full extent of the law. (Dates of issuance and the results shown in this report are only for the sample(s) listed and such sample(s) are retained for 180 days only.)

14. Hazard Substance Analysis



Test Report No. F690501/LF-CTSAYAA11-02162

Issued Date: January 21, 2011

Page 3 of 5

Sample No. : AYAA11-02162.001
Sample Description : 3535 Ceramic PKG
Item No./Part No. : N/A
Comments : Materials are Ceramic, Silicone.

Halogen Contents

Test Items	Unit	Test Method	MDL	Results
Bromine(Br)	mg/kg	BS EN 14582:2007 , IC	30	N.D.
Chlorine(Cl)	mg/kg	BS EN 14582:2007 , IC	30	N.D.
Fluorine(F)	mg/kg	BS EN 14582:2007 , IC	30	N.D.
Iodine(I)	mg/kg	BS EN 14582:2007 , IC	50	N.D.

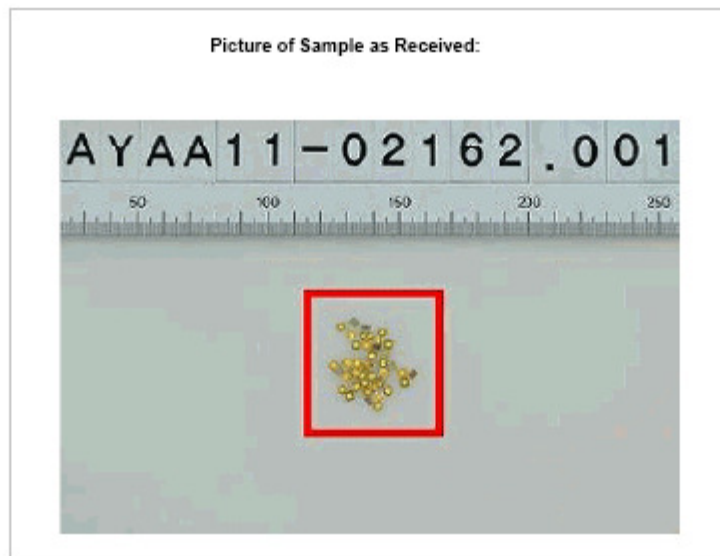

- NOTE:**
- (1) N.D. = Not detected.(<MDL)
 - (2) mg/kg = ppm
 - (3) MDL = Method Detection Limit
 - (4) - = No regulation
 - (5) ** = Qualitative analysis (No Unit)
 - (6) * = Boiling-water-extraction:
 Negative = Absence of CrVI coating
 Positive = Presence of CrVI coating; the detected concentration in boiling-water-extraction solution is equal or greater than 0.02 mg/kg with 50 cm2 sample surface area.

This document is issued by the Company subject to its General Conditions of Service placed on order, available on request at www.sgs.com and, for electronic format documents, subject to Terms and Conditions for Electronic Documents at www.sgs.com/sgs_electronic_documents. Attention is drawn to the limitation of liability, indemnification and limitation clauses stated therein. Any holder of this document is advised that information contained therein reflects the Company's findings at the time of its issuance only and within the limits of Client's instructions, if any. The Company's sole responsibility is to its Client and this document does not constitute parties to a transaction from whom any claim, rights and obligations under the transaction documents. This document cannot be reproduced except in full, without prior written approval of the Company. Any unauthorized alteration, forgery or falsification of the content or appearance of this document is strictly prohibited and may be prosecuted to the full extent of the law. (Dates otherwise stated are the results shown in this test report refer only to the sample(s) tested and each sample(s) are retained for 90 days only.)

